

# **Performance Hoist**

**PH9A 2 POST SPECIFICATION SHEET \$3,995**



If you're looking for a hoist for maintenance and repair, want to save a bit of space, consider a 2 post lift. The PH9A is a floor-based design so requires less overhead clearance. Driven by an electric motor over a hydraulic pump, it uses a wire rope drive, so is quiet to operate. The built-in ladder lock system allows for working height adjustment and safety. The bilateral manual unlocking makes it convenient to use. Design has been CE certification tested, 120% dynamic load tested and 150% static load tested.

## **Specifications:**

Lifting capacity	9,000 lbs
Outside width	132"
Width between posts	110"
Height of posts	109"
Lifting height	72"
Lifting time	50 sec
Lowering time	40 sec
Motor power	2.2 kw
Power Supply	220v

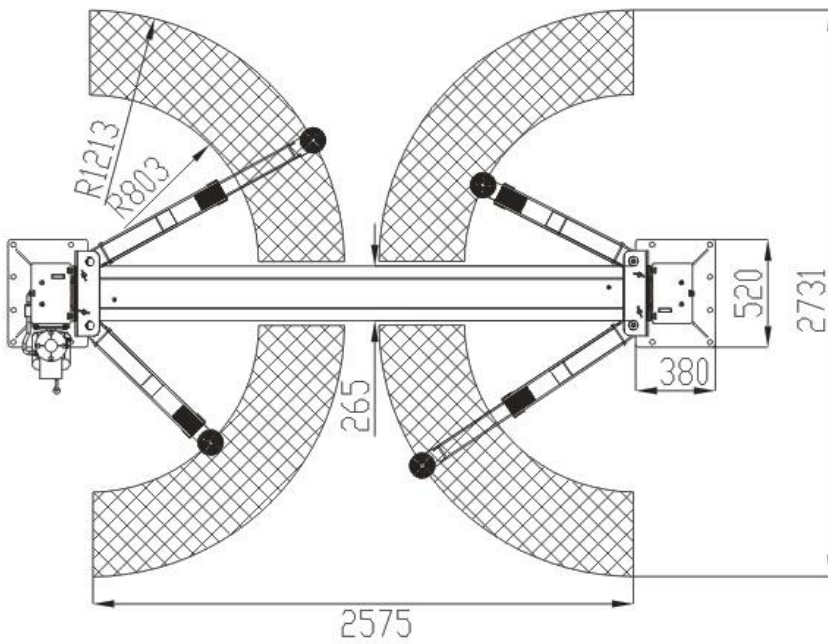
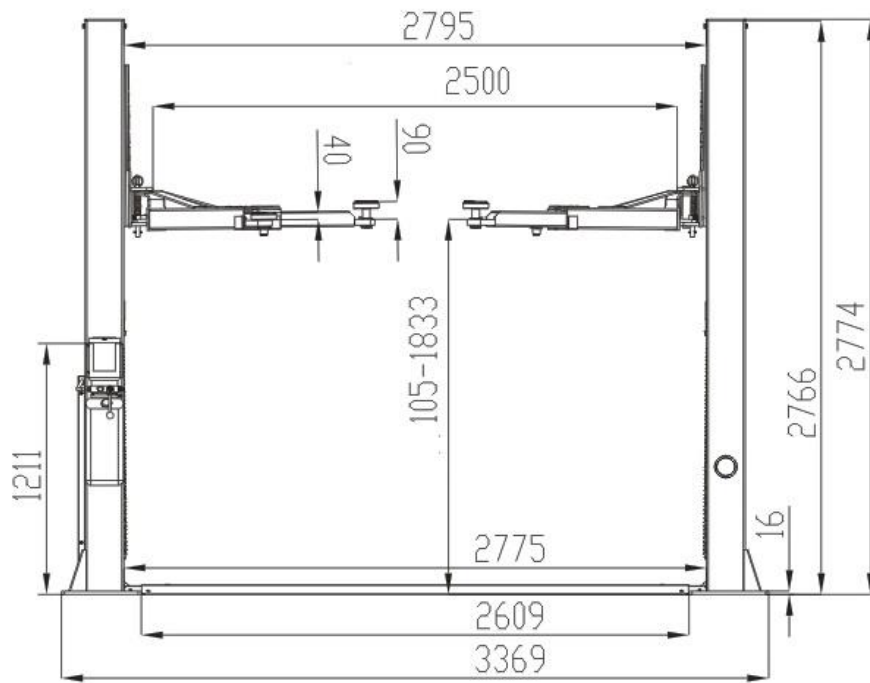

Measurements in metric

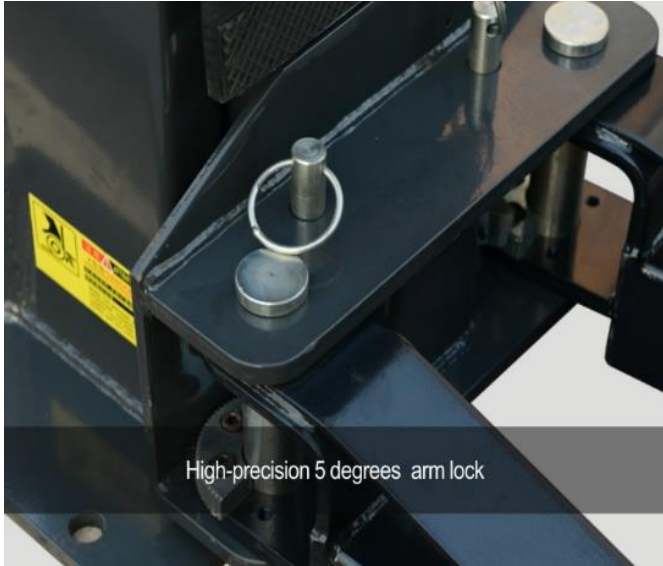

High-precision 5 degrees arm lock

High precision 5 degree arm lock



Bilateral, manual lock release

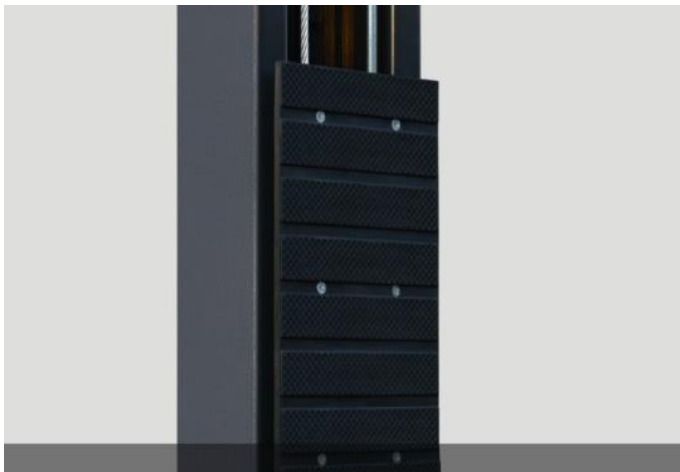

Rubber, protective door bumper



2-stage Screw-up pads

Screw adjustable pads

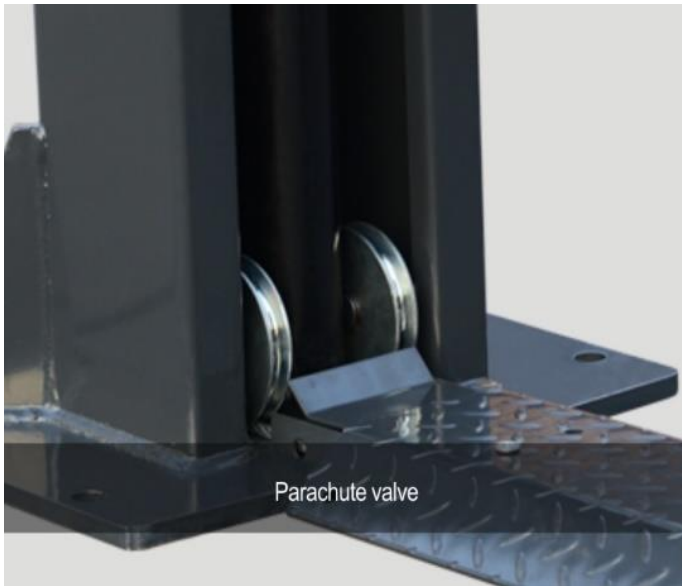

Parachute valve

Parachute valve

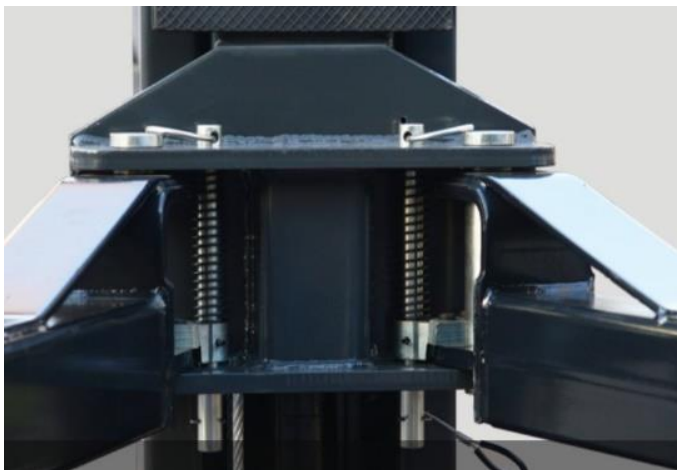

Strengthened carriage inner-arm lock